

## INTEGRATING PUMPED HYDRO STORAGE WITH RENEWABLE ENERGY TO IMPROVE GRID LOAD MANAGEMENT

Afaq Khalid<sup>1</sup>, Khalid Rehman<sup>\*2</sup>, Kiran Raheel<sup>3</sup>, Zaheer Farooq<sup>4</sup>

<sup>1,2,3,4</sup>Department of Electrical Engineering, CECOS University of IT & Emerging Sciences Hayatabad, Peshawar 25000, Pakistan

<sup>1</sup>afaqkhalid321@gmail.com, <sup>2</sup>khalid@cecos.edu.pk, <sup>3</sup>kiran@cecos.edu.pk, <sup>4</sup>zaheer@cecos.edu.pk

DOI: <https://doi.org/10.5281/zenodo.20676267>

### Keywords

Pumped Hydro Storage System (PHSS), Wind Turbine Model, PV Model, Hybrid Hydro-Wind-Solar Solutions (HHWSS), New Power Generation, Hydro Generators, Technical Feasibility.

### Article History

Received: 16 April 2026

Accepted: 28 May 2026

Published: 13 June 2026

Copyright @Author

Corresponding Author: \*

Khalid Rehman

### Abstract

This research presents a multi-criteria evaluation technique for a sustainable mechanical arrangement that incorporates renewable sources. It investigates the most compelling methods to use the combined control of solar, hydro, and wind power to solve the difficulties of flexible, viable, and tried and true energy capacity. Scientific reenactments with cross-breed arrangements are created using a variety of constraints and working standards. An electrical development framework based mostly on wind and solar technologies, as well as pumped-storage hydropower plans, is drawn out in order to determine how much renewable energy and capacity are necessary to satisfy renewables-only era goals. The proposed strategy in the current study blends pumped hydro capacity innovation with a cross-breed sun-based wind turbine framework (a renewable vitality source) to alleviate vitality shortages while safeguarding network stability. Solar and wind power are inherently unpredictable and untrustworthy sources of energy. As a result, they cannot guarantee the critical stack request. However, by integrating these two renewable resources (solar panels and wind turbines) into a pumped hydro capacity configuration, the effects of fluctuation in solar and wind resources may be mitigated, making the overall system more predictable and economically sustainable to operate. According to the research, the most practicable strategy to achieving this goal is to combine pumped hydropower with solar and wind energy. The findings indicate that, in terms of feasibility and coherence, pumped hydro capacity combined with solar and wind energy is the best option for achieving energy independence.

### INTRODUCTION

The world's population is using more and more electricity, and because fossil fuels cause environmental pollution, nations are accelerating the creation of green energy. The mixture of photovoltaics and wind generators is thought to be the most advantageous method for producing pure and affordable energy, and this method is especially advantageous if the systems are linked to

the grid [1]. Increased integrating sources like wind and solar into current power networks may pose serious technological difficulties, especially in cases where stand-alone technologies lack sufficient storage or weaken grids, because they are inherently intermittent and unpredictable. The influence of the erratic character of solar and wind resources can be lessened through incorporating pumped hydro with green resources as effectively as feasible. Combining renewable energy with

energy storage systems is the greatest way to deal with energy shortages since it reduces the effects of climate change, boosts power system stability, and enhances storage capacity. Energy storage devices can be utilized as a flexible and stable backup power source for intermittent renewable energy sources by storing excess electricity and releasing it when needed to replace periods of net load [2]. Many researchers worldwide are working to overcome the inconsistent nature of renewable energy since any advancement in this technology would encourage more people to convert to clean energy sources like wind and photovoltaics [7]. This study's proposed PHS would deal with the RES issue.

#### PROBLEM STATEMENT

Given that they are sporadic sources of electricity, demand for wind and solar energy can never be adequate. Coordination and incorporating pumped hydro systems can address this issue by pushing water to higher reservoirs when there is more power and less demand. When there is a surplus of water but not enough to meet demand, the turbines can be powered by water pumped from the upper reservoirs. The plan demands for careful consideration of site selection as well as the particulars of the PV, wind, and pumping hydro systems even though the demand and supply gap is managed. The incorporation and control of system components must be advised, along with a detailed examination of generation and load pat

#### CONSEQUENCES

There are several sizes and styles of storage. The technique known as conventional hydropower is recognized for its ability to generate and store energy, but there are two more possibilities: pumped hydro and huge batteries. In tiny microgrids, batteries are the most popular kind of storage, despite a number of disadvantages. The costliest part of a microgrid is its battery [13]. It is divided into four cost categories: the starting cost, ongoing cost, maintenance cost, and repair cost. Furthermore, replacement costs are substantial due to its short lifespan. Another disadvantage of battery manufacture is the emission of greenhouse gasses [3]. Pumped storage power plants'

mechanical and electrical components have a lifespan of more than 40 years, and the lifespan dams are older than a century. PSH facilities may frequently supply 10 hours of power in contrast to lithium-ion batteries, and they also have an overall energy efficiency of greater than 80% [12].

#### MODEL FOR DISPATCH OPTIMIZATION

According to the indicated numerical demonstration, a cross-breed renewable energy arrangement may be created by integrating wind, solar, and pumped hydro-storage vitality capacity. Wind is one of the most erratic climatic components, varying hourly and annually simultaneously. By incorporating the wind energy into the framework, which provide high-quality control supply, large energy capacity devices are necessary. However, depending on their control bend characteristics, different types of wind turbines may produce varying quantities of electricity. A current presentation must be used to characterize the execution [20–23]. Although solar energy is more reliable, it is only available during the day. The quantity of vitality capacity devices essential to generate more constant power is quite little. It might also be committed to and operated with the intention of providing tested and true, progressive control [24]. According to [25], pumped hydropower capacity offices provide a variety of options. A coordinates framework consists of four important components: (1) quick response times and adaptable start/stop; (2) the ability to monitor stack changes and respond to significant changes in a stack; (3) recurrence tweak and voltage soundness; and (4) resistance to climate change and reduced impression affects. A crossover solar-wind framework supported by a pumped-based hydro plot can improve its overall technical and financial performance by utilizing the best plan possible. Multi-variable techniques are well-known for their precision and simplicity when dealing with difficult optimization problems. Figure 1.1 shows the optimization methodologies for hybrid hydro-solar-wind systems. The primary goal is to determine if such a system can store excess solar and wind energy for use when demand is low, generate hydroelectric power during high demand, or become self-sufficient.

This graph, which anticipates hourly fluctuations or 8760 cycles, was created using accurate data on variations in control demand and wind/solar essentialness period throughout the course of a typical year. Figure 1.1 depicts the recommended course of action for wind, solar, and pumped-storage energy coordination with the corresponding closed-loop celerity system.

The intended capacity option is pumped hydro capacity (PHS), which consists of a restricted pump/motor unit and a turbine/generator unit that incorporates inputs from additional renewable sources to meet the capacity requirement [26]. The water pumping coefficient (m<sup>3</sup>/kWh) and turbine producing coefficient (kWh/m<sup>3</sup>) in Conditions 2 and 3, respectively, are two critical parameters for the PHS component 1. The following condition describes the overall demand for E<sup>t</sup> (in kWh) inside a store's energetic volume:

$$E^t = P^t = \rho \times H \times g \times \eta_t \times Q$$

Where:  $\rho \times H \times g \times \eta_t = C_t$

$$\text{Then } E^t = P^t = C_t \times Q \quad \text{Eq (1)}$$

The equation for calculating the vitality required to pump a certain volume of water

when utilizing a specific pumping effectiveness is;

$$E^p = \frac{\rho \times g \times H \times V}{\eta_p}$$

Where  $c_p = \frac{\rho \times g \times H}{\eta_p}$

$$\text{Then } E^p = c_p \times V \quad \text{Eq (2)}$$

Where H is the pumping head, C<sub>p</sub> is the pump's water pumping estimation, and η<sub>p</sub> is the pump's input and yield control. Water is taken from the upper supply to run the hydro turbines in times when there's not enough vitality. To realize the ideal comes about in terms of vitality utilization, productivity, take a toll, and footprint, the prescribed expedited demonstration moreover chooses the foremost viable set of top parameters. The proportion of added up to stream to normal day-by-day stream is called the crest calculate, and it is utilized in water framework examination to expect future water utilize. The rate of add-up to stream for enormous water frameworks as a rule falls between 1.2 and 3.0, and for certain little frameworks, it may indeed be higher. When there is a shortage of power and water strained from the upper storage to control the hydro turbines.

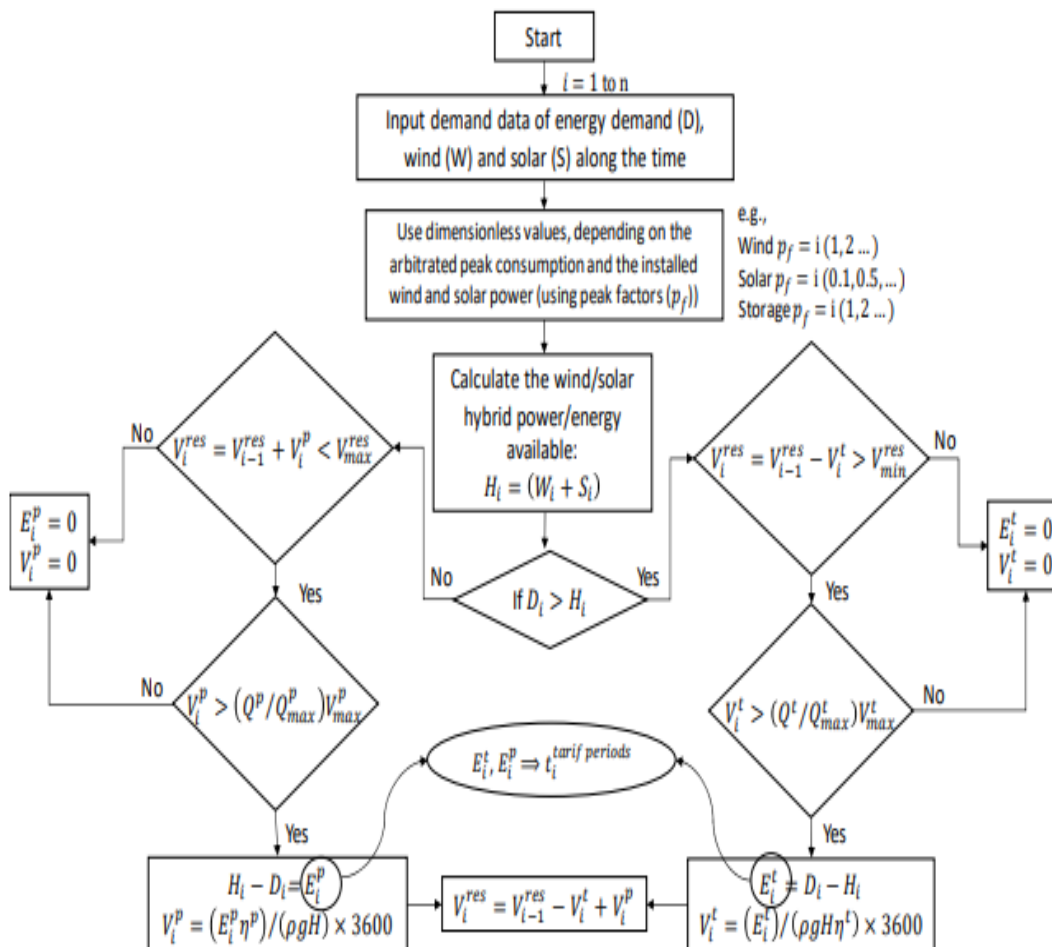

Figure 1.1. Use a flowchart to determine which half-breed system is ideal. The letters V, E, D, and S represent water volume (V), imperativeness (E), request (D), half-breed power/energy (H), sun-oriented essentialness (S), wind essentialness (W), and so on. The superscripts p, t, and rest represent a pump, turbine, and supply, respectively.

UTILIZATION OF ABUNDANCE USING WIND CONTROL IN PUMPED CAPACITY FRAMEWORK

The second part of the research focuses on the use of abundant wind energy in pumped capacity systems. This may be performed by examining the fundamental vitality levels and utility of these plants. Pumped storage is regarded as the best option for vitality capacity since it employs a tried-and-true technology, can store massive amounts of vitality, and can recover vitality fast and efficiently. The expanded supply, which might be used for the application and one of the water sources that are still operational, will be created by a dam or supply with a typically limited capacity sufficient for at least two or three days of progress. Another crucial

component is how efficiently and effectively hydro turbines shift over and store vitality into electrical vitality. Pumped capacity may be a well-established approach that has been used for at least the last eight decades. In the past, an excess of energy from heated control stations was stored in large-scale pumped capacity coordination using inverted hydro turbines. These frameworks were designed to operate when the request was trivial. Due to inconsistencies in the timing, length, and quantity of wind energy excess, projects that use pumping capacity to hold surplus energy from warm control plants perform differently than those that do not. The fundamental requirements governing the functioning of hydro-pumped capacity devices

have already been thoroughly investigated. The process of pumping water from a lower storage to a higher supply with an increase in  $h$  occurs during the vitality capacity stage, transitioning from an abundance of wind energy to water-powered vitality. During the recovery step, vitality is transformed into mechanical vitality, which is then converted into power. Water-powered turbines pump water from the upper to the lower supply.

#### SOLICITATION

This article examines three cases of wind-PV integration and the viability of systems with 1000 MW pumping capacity in the Greek energy system (3000-500, 5000-1000, and 8000-2000 MW). It is expected that a limited number of pumped capacity facilities, each with numerous pumps, would use pumping to capture excess wind energy. We compare the outcomes for the two atypical composition situations, A and B, as well as the pumping station's greatest and lowest degrees of adaptation.

There are two events.

**Case 1:** Three power plants had a 50, 100, or 150 MW capacity of each, along with five pumps and pumping stations.

**Case 2:** Three 333.3 MW pumps were housed in a pumping station at a single power facility.

The compositions of the pumping stations mentioned earlier are evaluated in terms of both the situation in which one pump at each station operates at a variable speed and the situation in which all pumps at the stations operate at the same speed. The total amount of extra wind energy that will be used for pumping, as well as the number of pumping stations, is computed and compared for each scenario shown in Figures 1. 2a and 1. 2b. To begin, if pumping occurs within a defined input control circle, variable speed operation is more flexible and efficient when using a single variable speed pump [10]. A single variable speed pump provides evident operational flexibility. As a

consequence, more of the available wind energy is used for pumping, increasing the pumping station's efficiency.

Therefore, influence of the variable speed pumps on component B is more noticeable. More important than the influence of variable speed pumps in composition A is the operational adaptability that the increased number and variety of pump sizes provides. The following disclosures were made in relation to the three wind-photovoltaic integration incidents that were investigated:

- In scenario I, a significant portion of the surplus wind energy—between 3000 and 500 MW—is put to use for pumping, but the actual utilization of pumping stations is rather low—less than 1%, even when there is just one variable speed pump.

- For scenario II (5000-1000 MW), a direct situation, the additional wind energy used for pumping ranges from 63 to 78%; nevertheless, the operation pumping stations are minimal, extending from 4.9% to 6.1% under the various analyzed situations.

- The amount of wind vitality excess used for pumping is significantly reduced (52-60%) in situation III (8000-2000 MW), which is the case with large-scale wind and PV integration, because the wind control that is reduced in many hours per year is far more prominent than the estimated control of the pumping stations. Nonetheless, a utilization rate of 14.8% to 17.1% falls somewhere in the center.

Finally, some tentative conclusions are drawn from the analysis. After the number of wind and solar installations steadily rises, the pumping power installed storage coordination in the Greek power coordination should also rise. Large capacity pumped storage systems would see extremely low usage. Conversely, a significant loss of wind energy would arise from extremely large solar and wind coordination capacities short of concurrently building pumped storage facilities.

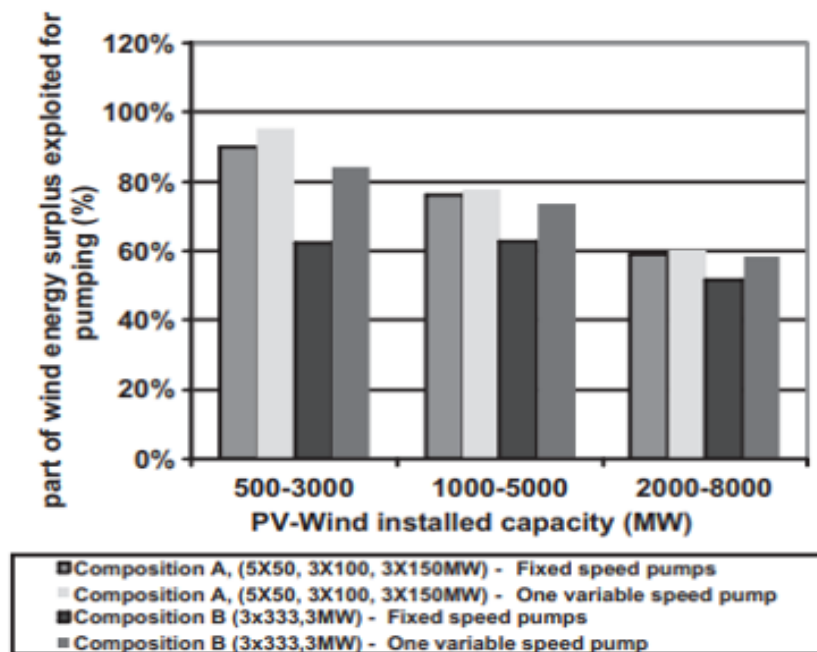

Fig 1.2a The rate of additional wind energy used for pumping, the total amount of pumping station utilization throughout the two pumping station composition scenarios, the three wind-PV integration scenarios, and the two scenarios with fixed speed pumps or one variable speed pump (up to 12 times).

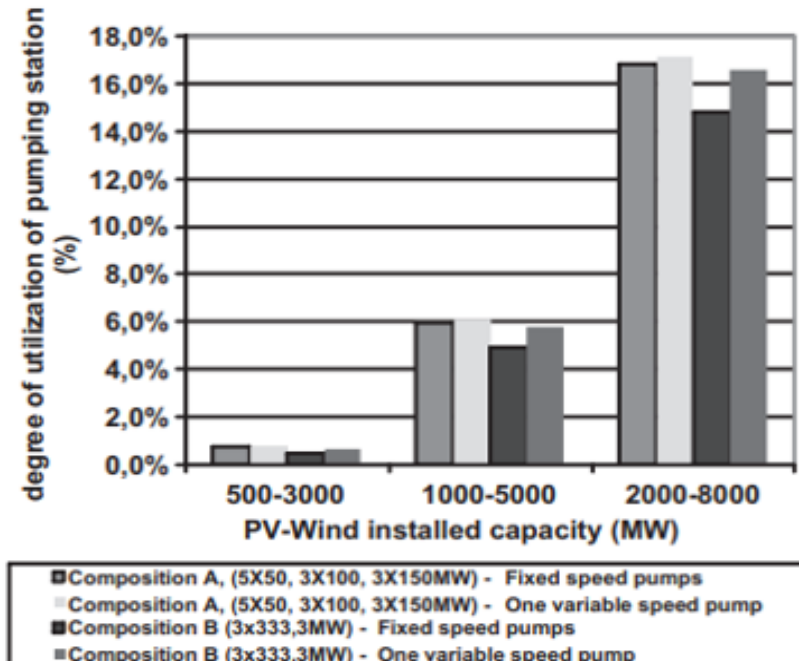

Fig 1.2b The rate of extra wind energy used for pumping, the total amount of pumping station utilization within the two pumping station composition scenarios, the three wind-PV integration scenarios, and the two scenarios with fixed speed pumps or one variable speed pump (up to 12 times).

The pumping stations are only used to a small amount (17%) even in the best-case scenario. (Scenario III, using 1000 MW of pumped storage devices and 10,000 MW of combined wind-PV capacity.) It implies that certain kinds of coordination could be useful in some circumstances. Adding pumping power from thermal power plants—the bulk of which use lignite—is one way to increase the plant's level of utilization. To fully use the plants, pumping activities that just employ extra wind energy are inadequate. Obviously, these facilities also provide ancillary services to the electrical system, which should be properly billed. The state power provider has provided these services to the Greek electrical coordination at no expense to date.

#### SIMULATION APPARATUS

*PASCAD, MATLAB and Visio:*

It provides the most appropriate and well-defended results for all types of electrical circuit layouts, as well as the most precise and competent computational disclosures.

#### OBJECTIVES

a) To reduce energy shortages while keeping the system able to meet load demands. Furthermore, the intermittent or unpredictable nature of renewable energy sources (such solar panels and wind turbines) may be resolved by combining them with pumped hydro storage systems.

b) To design model for coordinating, incorporating pumped hydro storage with renewable energy sources, and encouraging higher grid station load demand and keep energy on hand for when wind and solar energy production are at their peak. When the grid is underutilized and there is a significant demand for electricity, we will use this stored energy to balance the load.

c) To optimize and determine the system's potential locations and implementation methods. We will look into those areas from a variety of perspectives where this technology may be applied.

#### PUMPED HYDRO STORAGE SYSTEM

1.1. PHSs are storage systems that are typically used for load balancing purposes. A few Research has been done on the application of PHS in microgrids. In Figure 2.1, the PHS Schematic is displayed. It consists of two reservoirs, a pump, and a turbine. When the amount of power produced exceeds the amount needed, water is pumped to the top strata. When power output is not enough to satisfy demand, a turbine holds water in a reservoir and releases it back into the lower reservoir to create energy. Rather than electrical energy, it stores gravitational potential energy. The lower reservoir is often an actual lake or river, whereas the higher reservoir is typically an artificial lake. The PHS's carrying capacity is influenced by the reservoirs' combined volume & the difference in height between the two [3].

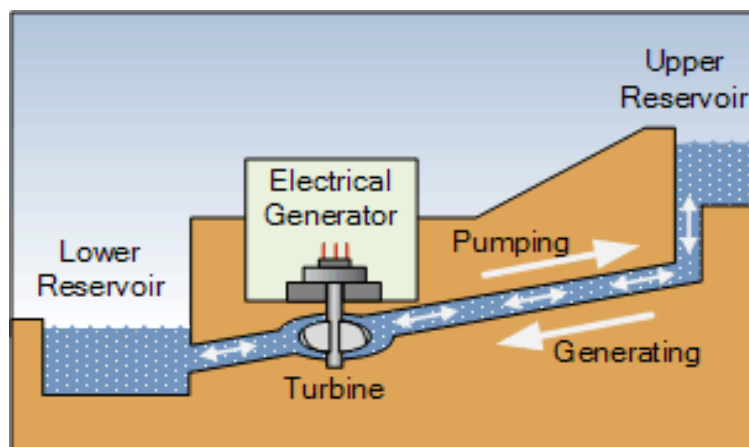

Figure 2.1. Schematic diagram of PHS

Pumped hydro (PHS) may be an intriguing type of control plant that combines utility and capacity. When compared to elective imperativeness capacity (ES) propels, PHS offers a reduced toll per unit, a longer life expectancy, consistent

essentialness change efficiency, and a less visible normal consequence. As a result, PHS is now the most practical type of high-capacity energy storage [4]. Table 2.1 depicts the vastly expanded base of pumped capacity frameworks over the world.

**Table 2.1.** Pumped capacity frameworks have been established across the world [5].

World	CAP (MW)
2011	1,092,993
2012	105,617
2013	106,856
2014	108,597
2015	111,853
2016	116,926
2017	119,833
2018	120,340
2019	120,828

**ASSESSMENT OF PHS TECHNOLOGY WITH BATTERY STORAGE TECHNOLOGY**

Energy storage research is still in its early stages, and a number of ESTs There isn't any commercial use of this as of 2016. Ignorance about several ESTs [15]. Lack of knowledge may make it

challenging to choose which storage technology is best for a certain application and to balance the benefits and drawbacks of modified technologies [8]. The In the table 2.2 battery storage and PHS technology evaluation is displayed.

**Table 2.2.** The following is an assessment of PHS and battery capacity developments.

PHS Technology	Battery Storage Technology
Mature Technology	Short Life Time
No/less maintenance Cost	Maintenance Cost (High)
Long lifetime	Corrosive Behavior (High)
Environmentfriendly	Toxic Substances available
Large storage Capacity	Initial Investment (High)

**CO-ORDINATION OF PV WIND (AMALGAM SOLAR)**

As global warming and the use of fossil fuels increase, many people are looking for economical energy solutions to ensure that the land remains safe for future generations. Aside from hydropower, wind and solar power are the best options for meeting our energy demands. In fact, while wind energy has the ability to provide significant control over its claim, it may suddenly become dominant one day and then disappear the next. Sun-oriented essentialness is also available throughout the day; however, its quality varies

based on the sun's location and the unique shadows cast by the sun, clouds, animals, and other things [9]. Combining these two spasmodic sources and using the Foremost Extraordinary Control Point Taking the following can significantly improve the system's control gearbox adequacy and reliability [10]. A half-breed vitality framework is composed of components from two or more different types of control-creating frameworks. For this study, a hybrid renewable energy system powered by wind turbines and solar energy is used. Given that the control generation of multiple renewable energy sources is eventually

influenced by climatic variables such as temperature, solar power introduction, wind speed, and so on. A suitable Hydro Pumped Storage system is incorporated to steady the system output. Two different forms of energy are coordinated by the hybrid energy system [6]. An integrated hybrid renewable PV-wind energy system consists of an inverter, storage system, solar PV, wind turbine, and many auxiliary parts. A range of models for the PV-wind combination are employed in order to fulfill load demand. While the vitality sources (sun and wind) are sufficient, abundance control is transferred to the capacity framework. When renewable energy sources (wind and PV) are insufficient to meet demand, the vitality capacity framework is used until capacity is depleted [7]. Cross-breed solar and wind energy generation systems are a very appealing option for stand-alone applications. Combining solar and wind energy sources can improve framework reliability and minimize operating costs since the two systems' attributes can be used to balance each other out [1].

#### WIND VITALITY CO-ORDINATION

Global energy consumption is currently changing in favor of green energy, or renewable energies.

The technique of using the wind to generate mechanical or electrical energy is known as wind energy or wind power. The growing global need for energy and environmental concerns are making wind energy an increasingly appealing option for establishing control. Carbon dioxide, one of the gases released into the atmosphere by burning fossil fuels, contributes to global warming. Wind vitality may provide electricity without the need for fossil fuels. A wind turbine is a popular wind power conversion device that converts wind energy into electrical energy. It consists of three major components.

The two or three fiberglass edges that comprise the turbine's rotor are linked to a center by water-powered engines, allowing each edge to be balanced to the wind speed at any given time. As a consequence, the turbine can operate efficiently at a variety of wind speeds. The nacelle, a massive cage behind the rotor, contains the generator, gearbox, driving shaft, and transformer. To maximize wind vitality absorption, the nacelle is frequently placed above a piece of yaw equipment that rotates the rotor and nacelle such that the wind is constantly parallel to the rotor plane. The tower supports the rotor and nacelle. Figure 2.2 shows a schematic illustration of a wind turbine.

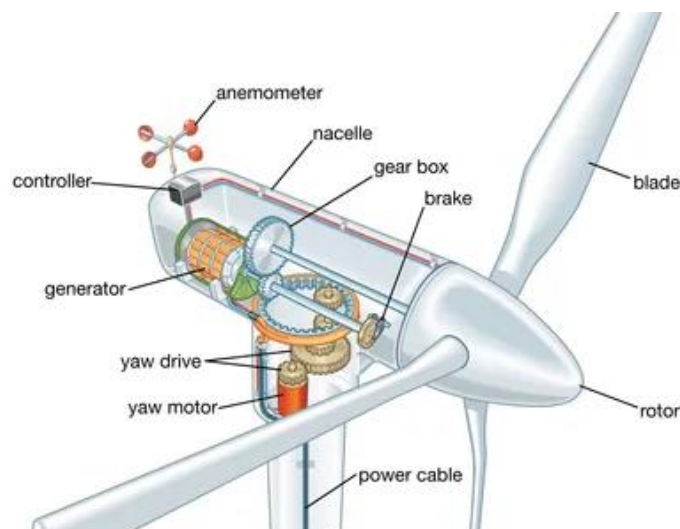

Figure 2.2. Wind turbine diagrammatic example [31].

Because the rotor and generator have different operating speeds, the wind turbine uses a shaft and

gearbox system to convert motor energy in the wind into mechanical energy. The generator

converts mechanical energy into electrical energy. Additional mechanical control can be used for practical applications such as pumping water or pulverizing grains. Ordinary exercises can be conducted using the control you've developed. In addition to other applications, it may be used to regulate homes, workplaces, clinics, and other enterprises. It may be used to govern homes, work

environments, rehabilitation facilities, and other educational settings, among other things. The key components of the wind energy frameworks that will be modelled are listed below: The wind, turbine, shaft and gearbox, generator, control, and other models are depicted in (i), (ii), (iii), (iv), and (v) in that order. Table 2.3 summarizes the total number of wind turbines delivered.

**Table 2.3. Global Wind Turbine Capacity [5].**

World Wise	CAP (MW)
2011	220,019
2012	266,908
2013	299,919
2014	349,300
2015	416,248
2016	466,864
2017	514,374
2018	563,830
2019	622,249
2020	733,276

#### SOLAR VITALITY COORDINATION

The sun warms and illuminates our bodies simultaneously. Sun-powered control frameworks are divided into two categories: sun-based warm frameworks, which store warm water, and sun-oriented photovoltaic frameworks, which directly convert daylight into electricity. When PV modules are exposed to sunlight, they produce coordinate current ("DC" power). Sun-powered vitality may be easily converted into power using photovoltaic cells. Light strikes the junction of two separate semiconductors or the intersection of a metal and a semiconductor (such as silicon) in these cells, delivering a modest electric potential.

A single sun-oriented cell may typically provide around two watts of control. A sun-based control plant may generate hundreds or even thousands of kilowatts of electricity, as can a large private cluster formed by joining several cells, similar to sun-oriented board clusters. Because sun-powered light is becoming increasingly prevalent, large and expensive clusters of photovoltaic cells are necessary to give really direct quantities of control. The majority of solar cells available now have a 15-20% energy efficiency. Table 2.4 displays the introduced capacity of solar-powered photovoltaic facilities across the world.

**Table 2.4. Sun-powered photovoltaic plant capacity introduced globally [5].**

World Wise	CAP (MW)
2011	72,040
2012	101,449
2013	135,681
2014	171,590
2015	217,463
2016	291,295
2017	384,452
2018	482,916

2019	580,760
2020	707,495

FUNDAMENTAL ASSENTING MODELS  
IMPORTANT MARGINS & EFFECTIVE  
IDEOLOGIES

Hydroelectric generation occurs during peak hours (i.e., when there is the maximum demand), whereas pumping occurs during off-peak hours. As a consequence, during off-peak hours, wind and solar energy were used to generate electricity, with hydropower supplied to the control system during Conditions of Operation:

$$\frac{q_{mi}^P}{q_{mx}^P} v_{mx}^P \blacksquare v_j^T \Rightarrow \frac{q_{mi}^T}{q_{mx}^T} v_{mx}^T \quad \text{Eq (3)}$$

$$v_{mi}^{re} \Rightarrow 0.16v_{mi}^{re}$$

$$v_j^{re} \rightarrow v_{j-1}^{re} + v_j^P - v_j^t$$

$$e_j \rightarrow h_j - d_j$$

Limitations considered:

Condition;  $v_j^{rs} \Rightarrow v_{mx}^{rs} \rightarrow v_j^P = 0$

Otherwise;  $v_j^P = \frac{E_j^P \eta^P}{\rho g H \times 3600} \times 1$

Condition;  $v_j^{rs} \leq v_{mi}^{rs} \rightarrow v_j^T = 0$

Otherwise;  $v_j^T = \frac{E_j^T}{\rho g H \eta^T \times 3600} \times \frac{2}{2}$

If there is time = at a time when demand is low  $\rightarrow E_j^P =$ Electricity installation for pumps,  
 $E_j^T = 0$

Otherwise;  $E_j^P = \text{zero}, 1 \times E_j^T = -\Delta E_j \times 1 \quad \text{Eq (4)}$

DAILY SCHEDULE OF POWER STREAM

Figure 1.1 and Table 1.1 illustrate how  $E_j^T$  and  $E_j^P$  are affected by tri-time duty. Because the pumping system operates in the early morning (0-7 h), it has

the remaining hours if inadequate solar and wind energy production was discovered. The framework makes use of a large amount of solar and wind energy that is not necessary for pumping. This reduces the fetch required to get control of the lattice. The operational limitations of Condition (3) and the continued working conditions of Condition (4) are depicted below [2]:

sufficient savings to withstand the intermittent disappointments of the renewable energy age for the remainder of the period. The tri-time job determines the daily cycle of electricity supply in Portugal's terrain. Table 3.1 illustrates this cycle.

Table 3.1 The daily tariff periods are displayed

Days	Tarif Period	Winter	Summer
Workdays	Peak	5 h/day	3 h/day
	Half-peak	12 h/day	14 h/day
	Normal off-peak	3 h/day	3 h/day
	Super off-peak	4 h/day	4 h/day
Saturdays	Half-peak		7 h/day
	Normal off-peak		13 h/day
	Super off-peak		4 h/day
Sundays	Normal off-peak		20 h/day
	Super off-peak		4 h/day

### PHOTOVOLTAIC PROTOTYPE

Renewable vitality is essential to meet a country's vitality demands, and sun-based photovoltaic technology—which is clean and ecologically friendly—is critical in generating this vitality. To better understand how a sun-based photovoltaic (PV) generator will behave and function in the environment, it is necessary to show, replicate, and test the PV generator before deploying it anywhere. In the present configuration, a thorough, step-by-step reproduction in a MATLAB/Simulink environment emerges, along with a demonstration of a sun-oriented PV module with a single diode balancing circuit. The I-V and P-V chart of the sun-based PV module provides significant information for academics, producers, and communities. The ability of the photovoltaic (PV) model to faithfully reproduce the PV module's current-voltage characteristic bends is critical to the advancement of the PV era framework. In any event, the single PV display does not allow for a wide range of temperature and irradiance inputs to simulate the fractional shadow condition.

### COORDINATING PHOTOVOLTAIC RHEOSTATS

Changes in cell temperature and solar irradiation cause the output characteristics of the PV model to become nonlinear. Because of the unpredictable

nature of solar irradiation, the PV module's Maximum Power Point (MPP) varies over time. It takes a Maximum Power Point Tracker (MPPT) technology to operate the PV module at its maximum power point (MPP). This model will use an adaptation of the Perturb and Observe (P&O) MPPT control algorithm to control Maximum Power Point Trackers (MPPTs). The P&O algorithm operates by varying the PV array's operating current on a regular basis and comparing the PV output power to the prior number. If the PV array's operational point is positive, it is pushed in that direction; if not, it is moved in the control system in the other direction. MATLAB is used to create and implement an MPPT controller model, which allows the PV module to operate at its maximum power point. The P&O algorithm requires two measurements: the voltage ( $V_{pv}$ ) and the current ( $I_{pv}$ ). Temperature and irradiance are the two main inputs of the Simulink model of a photovoltaic array, which is seen in Figure 3.1. Temperature has an inverse relationship with solar efficiency, whereas irradiations ( $w/m^2$ ) are the number of radiations per unit area of a solar cell. The PV array in the suggested model is made up of 1061 parallel strings and 7 modules. 400KW is the result power and 25KV is the output voltage.

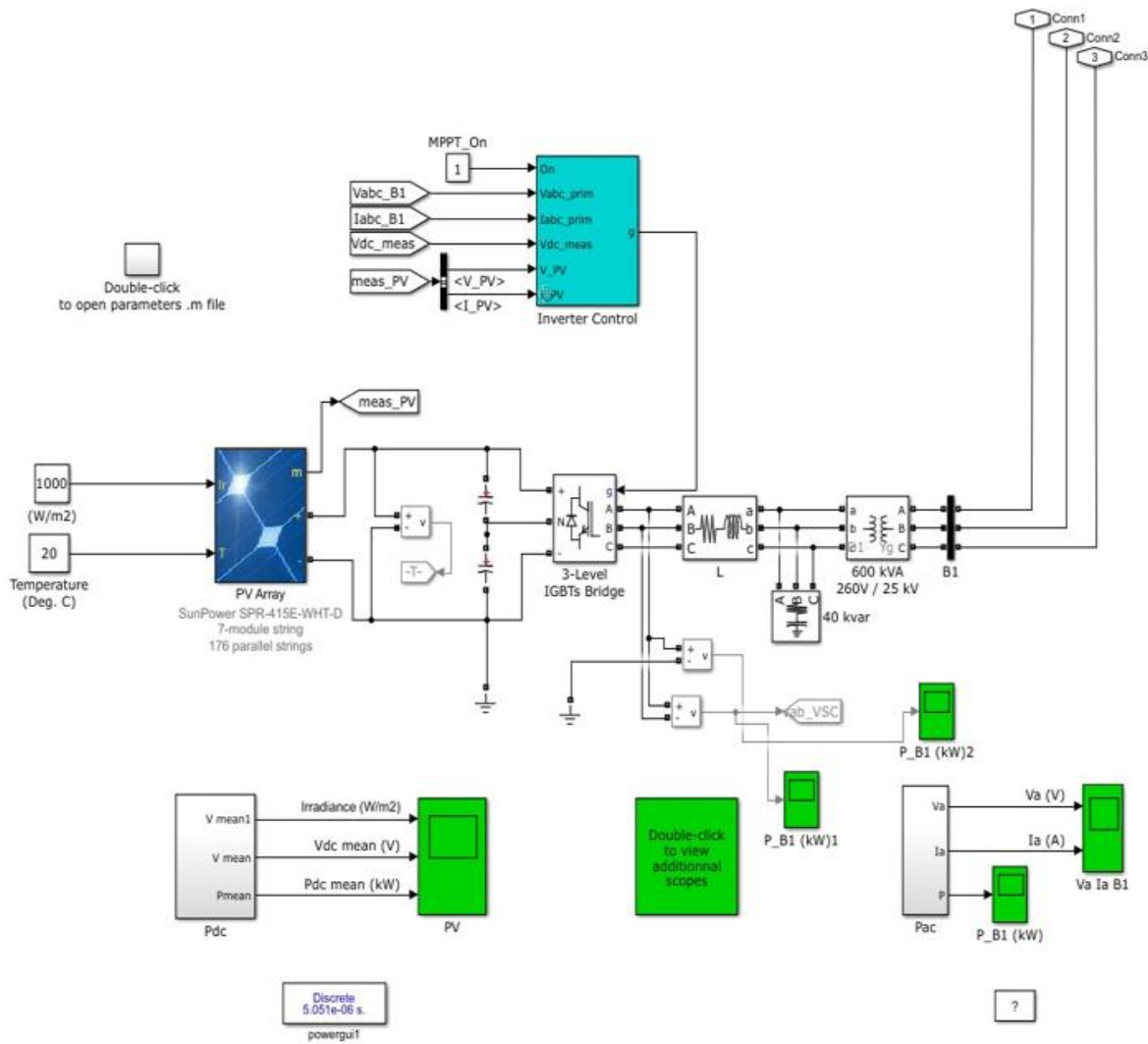

Fig. 3.1. Proposed model of PV with MPPT Controller, Output power 400KW and Output Voltage 25KV (Simulink).

### PROTOTYPE OF WIND TURBINE

As the environment changes, the unusual devices known as wind turbines—which are typically attached to the ground yet operate within the atmosphere—are subjected to a wide range of torques and stresses. Reenacting this behavior for land-based wind turbines is difficult enough, but modelling it for drifting seaward wind turbines presents even more issues since they may move in response to these circumstances and are subject to rolling waves, which may prevent their operation.

### FUNCTIONING STANDARD

The three blades that make up a wind turbine's main component are fixed atop a steel tower. Other, less common forms are steel or concrete lattice towers, or ones with two blades. The tower, situated at least one hundred feet above the ground, may help the turbine take advantage of the increased wind speeds at higher heights. By rotating blades that resemble wings and function as propellers, turbines capture wind energy. The wind caused a pocket of low-pressure discussion to form on one side of the edge. The edge is then dragged into the low-pressure discuss pocket,

causing the rotor to begin turning. Usually referred to as lift. Lift may be a far more fundamental limitation than drag, which is the weight of the wind on the driving edge of the edge. Because of the interplay of lift and drag, the rotor rotates like a propeller. The rotor's rotational speed is increased from around 18 revolutions per minute to over 1800 revolutions per minute via a series of gears, allowing the turbine's generator to generate alternating current power. The nacelle, a streamlined turbine component, often houses the gears, rotor, and generator. Helicopters may land on many of the turbine tower's nacelles. The turbine controller, which regulates rotor speeds to no more than 55 to 65 mph in order to cause downwind damage, is another critical component.

A persistent wind speed gauge, or anemometer, provides additional data to the controller. A nacelle brake uses mechanical, electrical, or hydraulic force to stop the rotor in an emergency. Examine the interactive picture above to learn more about how wind turbines operate. Wind energy has a rapidly growing installed capacity. Wind power is becoming more and more integrated, and by 2030, wind energy may account for 20% of the country's electrical energy. For this 20% target, 300 GW of installed capacity is needed [11]. Computer modeling and software simulation technologies have been developed by NREL researchers to give the wind industry state-of-the-art design and analysis capabilities.

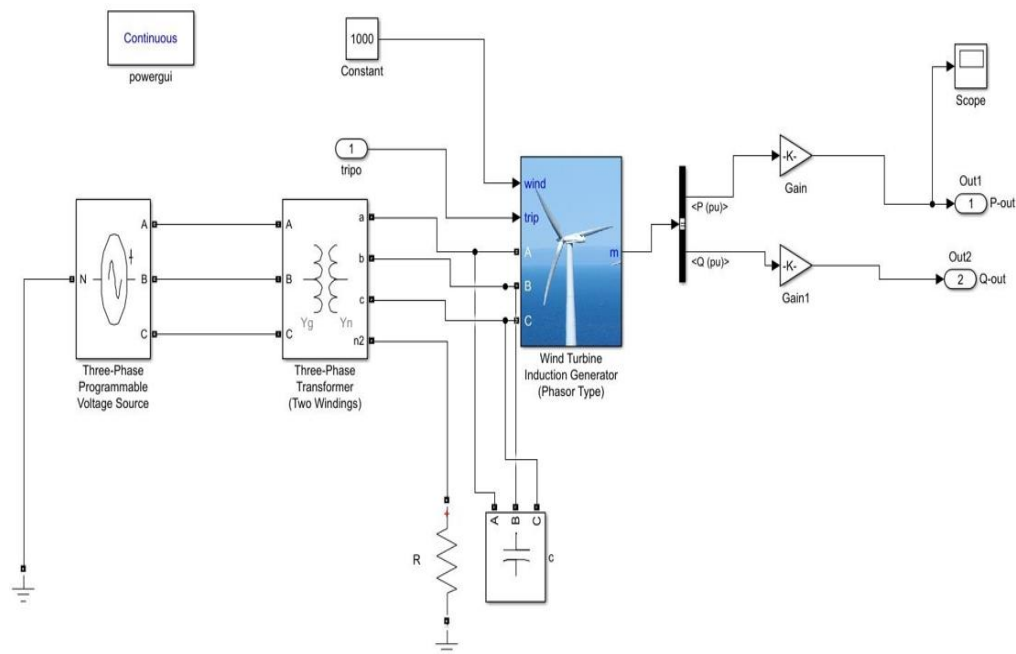

Fig. 3.2. 640KW output power of proposed wind turbine model (Simulink).

#### PUMP-HYDRO STORAGE SYSTEM MODEL

Pumped-storage Hydropower is one option for storing hydroelectric control (PSH). Using two water tanks at different elevations, the system generates energy (release) when water flows through a turbine and uses power (energies) to pump water to the lower supply. Pumped hydro vitality capacity (PHS) is a proven and commercially viable invention that has been used for utility-scale control capacity since the 1890s.

Hydropower is not a clean and cost-effective energy source, but it does have the versatility and capability to make gains in grid stability and stimulate the use of other distributed renewable energy sources, such as solar and wind. As a result, PHS is becoming more well known, and ancient modest hydro control plants are needed all around. Innovative tactics for optimizing capacity and enhancing plant productivity, as well as advancements in turbine planning, are necessary

to improve the adaptability and efficacy of plants in the deregulated energy market. This concept resurfaced early in the new millennium as a workable and economical way to lower peak demand and store solar and wind energy to guarantee the quality of the electricity. Because renewable energy sources fluctuate, they cannot be used to maintain or regulate a constant supply of power; large-scale electrical storage is thus required. The current study's objectives are to examine the world's display PHES capability, specialized innovations, and half-breed frameworks (wind-hydro, solar-based PV-hydro, and wind-pv-hydro), and to provide the most sensible solutions. The investigation reveals that the best innovation for tiny independent island lattices and enormous vitality capacity is photovoltaic vitality capacity frameworks (PHES),

whose vitality productivity varies between 70% and 80%, with some claiming up to 87%. While it may reach up to 3000 MW, the typical PHES measurement is between 1000 and 1500 MW. However, photovoltaic-based pumped capacity frameworks have traditionally been used for extremely small loads (many buildings).

**PUMPING RAMPANT**

Primary water-supplying pumping ranks of the distribution system will be located adjacent to a facility that purifies or stores drinking water. Water will be pumped straight into the pipe system by these levels. Three installed pumping stations are depicted in Figure 3.3 of our suggested model. Each pump has a three-phase circuit breaker and a 20KW rating. By adjusting the installed breaker, we may utilize these pumps as needed.

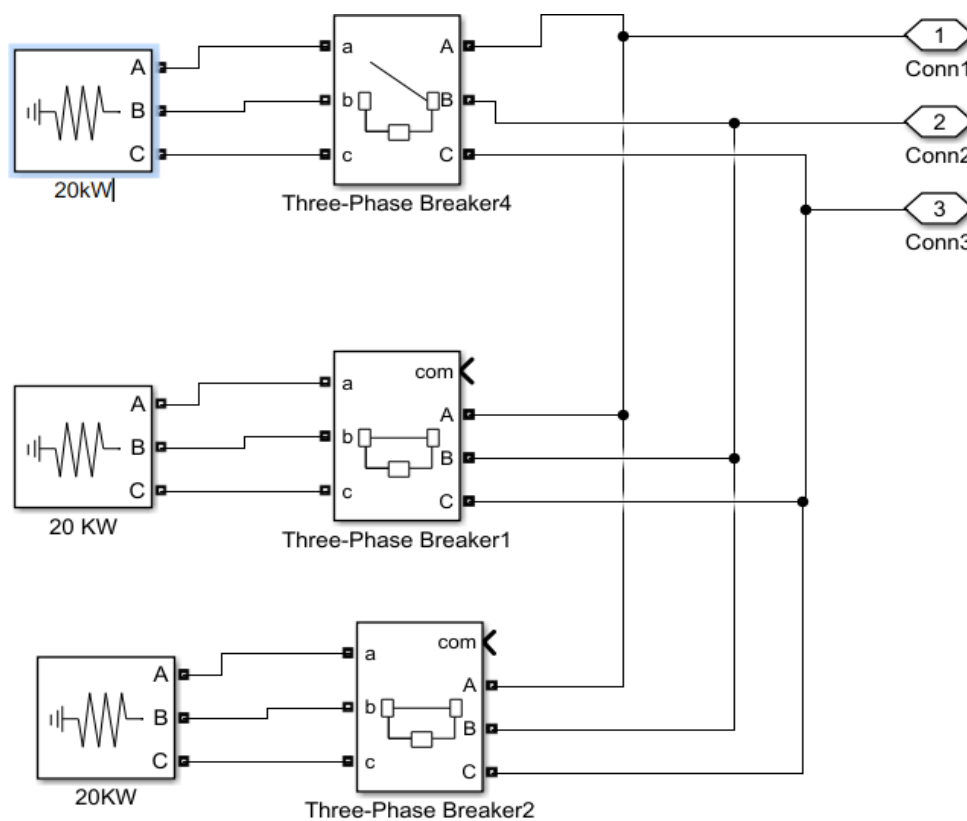

**Fig.3.3. Pumping Rank**

**HYDRO GENERATOR SIMULATION**

While other devices may be used to simulate the operation of a hydro turbine and synchronous generator, SIMULINK/MATLAB is the preferred

tool for simulating the flow of a hydro turbine and synchronous machine in this study. A schematic model of the hydro plant is created using the MATLAB SIMULINK programed.

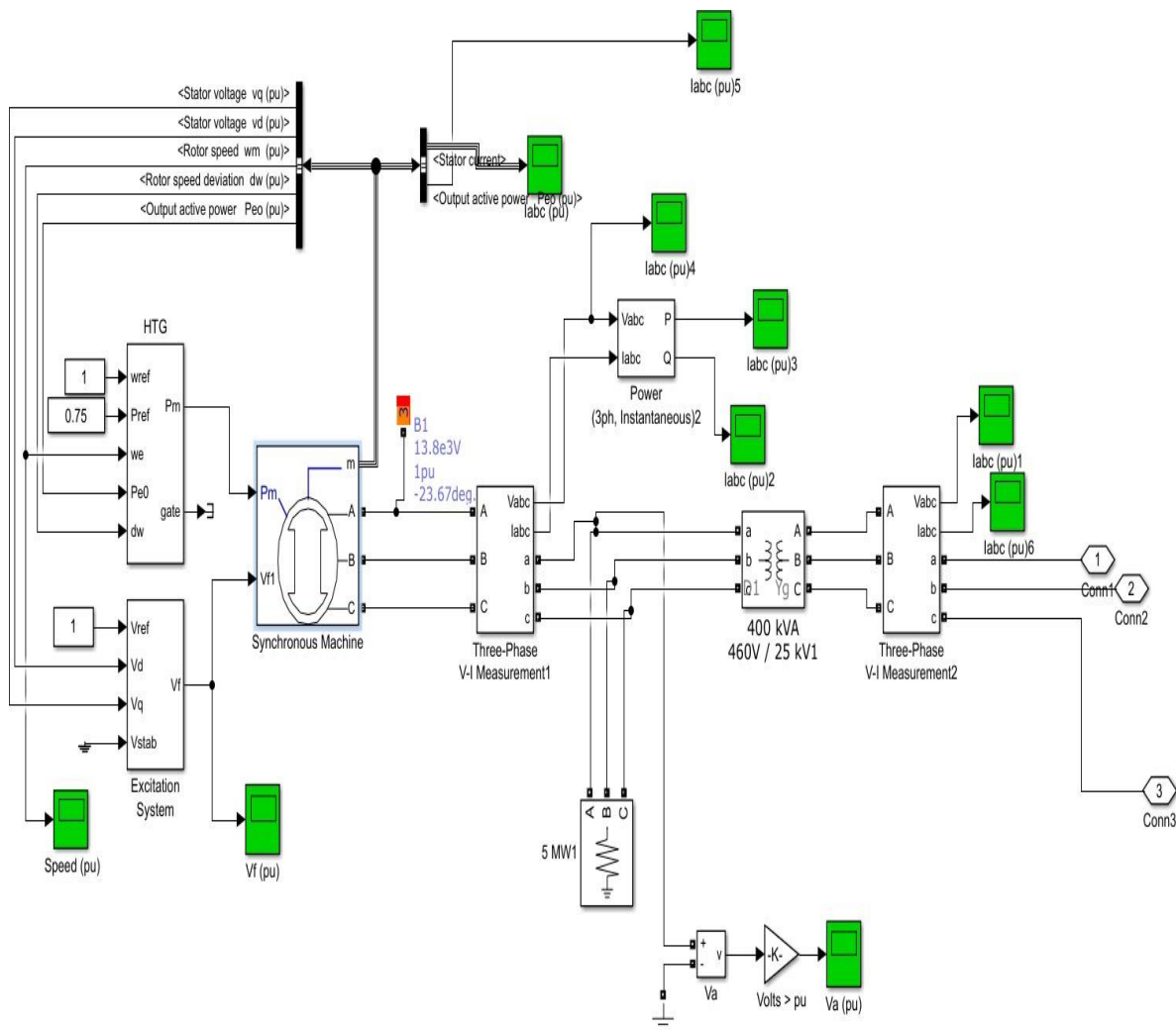

Fig.3.4: Simulink model of a 300KW hydro generator; two hydro generators with 25KV system voltages are installed in the suggested system..

THE PROPOSED APPRAISAL PLAN EXHIBITS LINKING AND COORDINATION VISIO PROTOTYPICAL

According to the suggested numerical demonstration, a crossover renewable vitality arrangement may be satisfied by calculating a specific quantity of solar, wind, and pumped hydro capacity. One highly changeable meteorological statistic that varies both hourly and annually is wind. Thus, it is essential to set up a system for integrating wind energy into the framework, provide a large energy capacity framework, and have a widely used control source. However, because of differences in their control bend characteristics, different types of wind turbines can

produce different quantities of electricity. A contemporary show ought to be used to describe the execution [20–23]. Sun-oriented energy is more consistent throughout the day, yet it is less erratic. It uses significantly smaller energy-capable devices and provides more consistent power. It makes use of remarkably smaller energy capacity devices and supplies. Pumped hydropower capacity offices provide some advantages, as stated by [25]. These focus areas include: (1) quick response times and flexible start/stop; (2) the ability to monitor variations in the stack and make necessary adjustments; (3) the capacity to adjust recurrence and maintain voltage stability; and (4) the capability to handle climate change and lessen

its effects on a coordinate arrangement. When paired with a pumped-based hydro plot, the most innovative half-breed solar-wind framework design has the potential to significantly advance both the technical and financial implementation for efficient energy utilization. Multi-variable techniques are notable for their accuracy and simplicity in solving complex optimization problems. In Figure 1.1 illustrates research idea half-breed hydro-solar-wind structure.

The main goal is to determine if such a framework can generate hydroelectric power at periods of high energy demand, store an excess of solar and wind energy during times of low energy demand, or become self-sufficient. This picture was created using detailed data on variations in control utilization and wind/solar essentialness period throughout the course of an average year, accounting for hourly variations or 8760 cycles. Figure 1.1 depicts the recommended method for planning renewable vitality sources, including wind, solar, and pumped capacity, as well as a comparison of closed-loop energy promptness planning. The vitality capacity plan of action that was considered was pumped hydro capacity (PHS), which consists of a portion turbine/generator unit and a pump/motor unit that coordinates inputs from other renewable sources to meet the vitality demand [26]. The water pumping coefficient (m<sup>3</sup>/kWh) in Condition (5) and the turbine-producing coefficient (kWh/m<sup>3</sup>) in Condition (6) are two fundamental characteristics of the PHS components (1). According to references [27, 28], the condition corresponds to the entire put-away imperativeness of an interior store's energetic volume.

$$E_t = P_t = (\text{in kWh}).$$

$$E^t = P^t = \rho \times H \times g \times \eta_t \times Q$$

$$\text{Where; } \rho \times H \times g \times \eta_t = C_t$$

$$\text{Then; } E^t = P^t = C_t \times Q \quad \text{Eq (5)}$$

Q is the stacking fitness (m<sup>3</sup>), c<sub>t</sub> is the turbine's producing figure (KWH/s<sup>3</sup>), g is the rate of change in speed, and ρ is the mass (kg/m<sup>3</sup>) per unit volume of water. "η<sub>t</sub>" is the generator's yield and input control (turbine/). H speaks to net head (m). To determine how much energy is needed to pump a specific volume of water with a specific pumping productivity, use the following equation:

$$E^p = \frac{\rho \times g \times H \times V}{\eta_p} = c_p \times V$$

$$\text{Where; } c_p = \frac{\rho \times g \times H}{\eta_p}$$

$$\text{Then; } E^p = c_p \times V \quad \text{Eq (6)}$$

Where η<sub>p</sub> is the pumping control input and surrender, H is the pumping head (m), and C<sub>p</sub> is the pump/motor's water-driving coefficient. When there is a lack of vital water, water from the highest capacity is used to power the hydro turbines. The recommended speed also selects the most practical mix of crest features in order to provide the best results in terms of vitality utilization, efficiency, toll, and impression. The best figure, which is used in water system analysis to increase future water usage, is the ratio of additional streams to regular streams. In large water frameworks, the amount of add-up to stream typically runs from 1.2 to 3.0, while in smaller frameworks, it can be greater.

In large water systems, the proportion of total flow typically ranges from 1.2 to 3.0, and in certain smaller systems, it can even be higher.

It is crucial to conduct tests and evaluate the performance of the suggested integrated based model against that of the currently in use-based models. The word "hydropower" describes the process of creating electricity by using the force of flowing water. Rain and melting snow in the hills and mountains generate rivers and streams that finally flow into the ocean. Using the energy of that flowing water to produce hydropower.

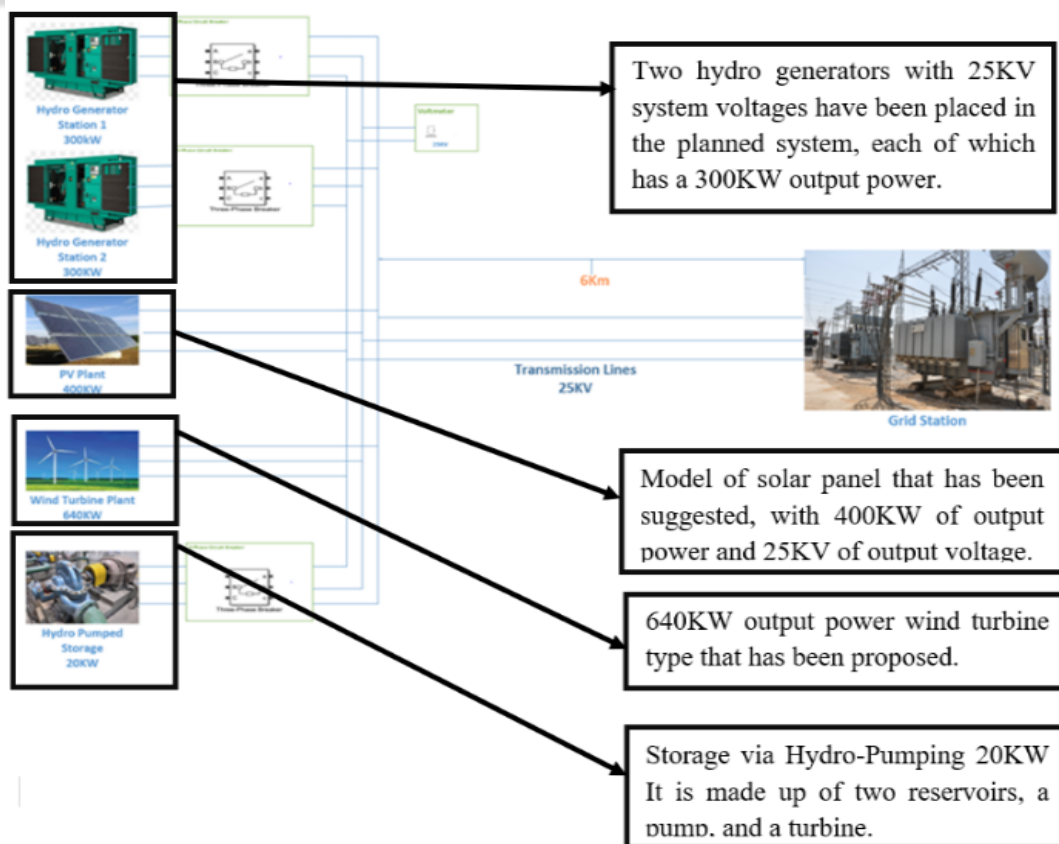

Figure: 4.1 The attached Visio model, which has 25 KV transmission lines connected to a grid station, offers the most lucid conclusion and justification for our effort.

Institute for Excellence in Education & Research

From the beginning of time, this energy has been used. Since the time of the ancient Greeks, farmers have used water wheels to convert wheat into flour. A water wheel buried in a river collects water, which is then rushed into buckets arranged around the wheel. The river's kinetic energy rotates the wheel, generating mechanical energy that powers the mill.

**PROTOTYPES COORDINATION & INCORPORATION (SIMULINK)**

The integrated circuit of our study is shown in Figure 4.2, where we have combined all of the component models—such as the pumps, hydro generator, wind, and PV models—to support and maintain the grid station.

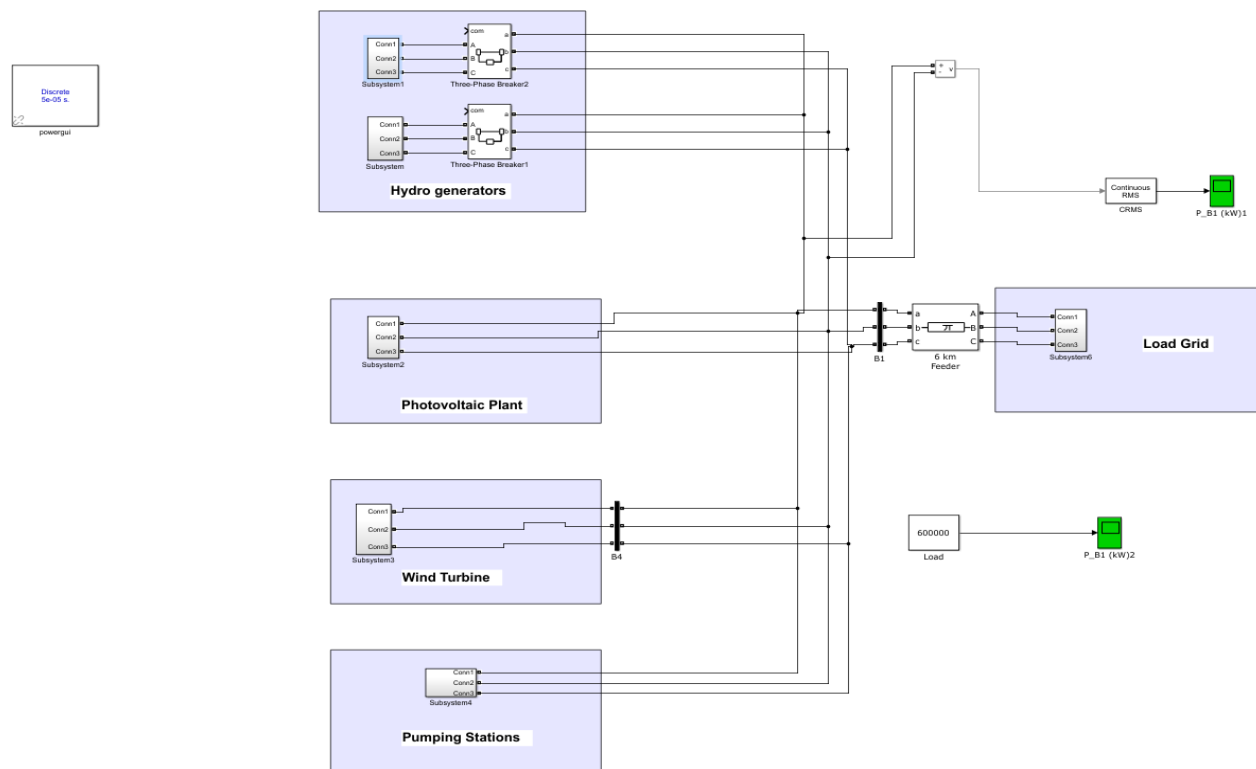

Figure. 4.2: Simulink Prototypes Incorporation

INSTANCES

Various instances can be used to explain Figure 4.2. These several scenarios will clarify how our suggested model operates.

1. When generated power exceeds the stack is shown in the Table below.

Table 4.1. The produced control is smaller than the Load.

Kilo Watts Load	200
PV(KW) Power Generated	400
Kilo Watts in Power Generated Wind Turbine	640
System Voltage (KW)	25
Pumping Power (KW)	40
Hydro Generators Status	Off
Total Power Generated (KW)	1040

Example No. 1 illustrates how, at the point where generated power exceeds demand power, we will activate the pumping station to move the extra power from the lower reservoir to the upper reservoir.

Voltage graph in Case No 1:

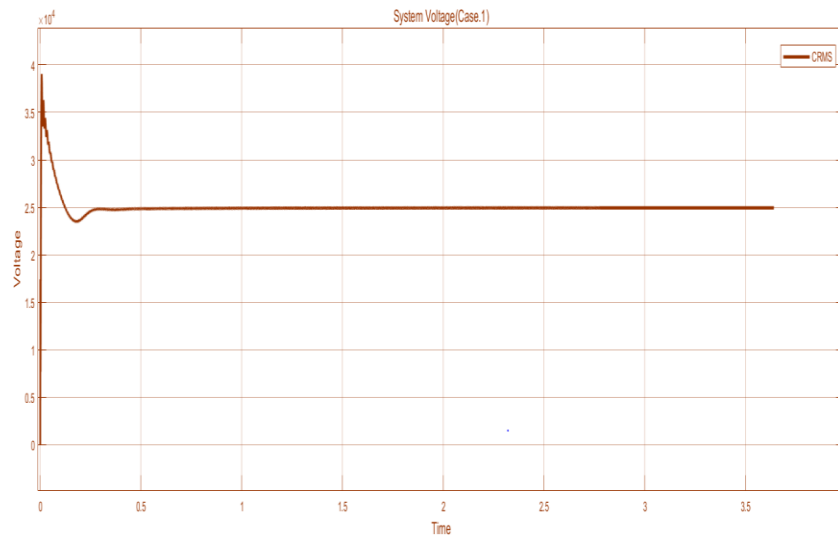

Figure 4.3.1. Showing the system's 25 KV output voltage indicates system stability and the usage of extra produced electricity for water pumping.

2. Table below shows what happens when the generated control and the stack are almost at the top.  
 Table 4.2. Before the load rises to the Created Control.

Kilo Watts Load	1000
Power Generated by PV(KW)	400
Power Generated by Wind Turbine (KW)	640
System Voltage (KW)	25
Pumping Power (KW)	Off
Hydro Generators Status	Off
Total Power Generated (KW)	1040

Instance No. 2 illustrates that in situations where the generated power is almost equal to the connected load, the pumping station must be turned off in order to stabilize the system since there isn't enough power to store water.

Voltage graph in case No 2:

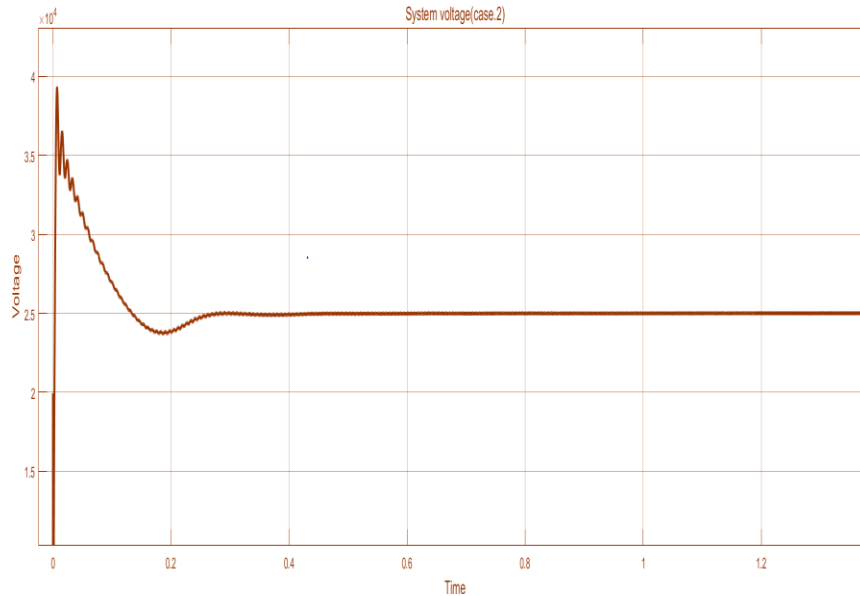

Figure 4.3.2 Show the system's output voltage, which drops significantly from 25 KV at first before stabilizing once the pumping is stopped.

3 (A). Table 4.3 lists the times when the hydro generators are not operating and the load is greater than the power generated.

Table 4.3. Generated power and Hydro generators are off, while load is bigger.

Kilo Watts Load	1600
PV(KW) Power Generated	400
Kilo Watts in Power Generated Wind Turbine	640
System Voltage (KW)	24
Pumping Power (KW)	Off
Hydro Generators Status	Off
Total Power Generated (KW)	1040

The system voltage drops to 24 KV in instance NO 3(A), indicating that the linked grid station is unable to meet the load demand and that the system is extremely unstable once generated power is not as much of connected load and hydro generators are off.

Voltage graph in Case No 3(A):

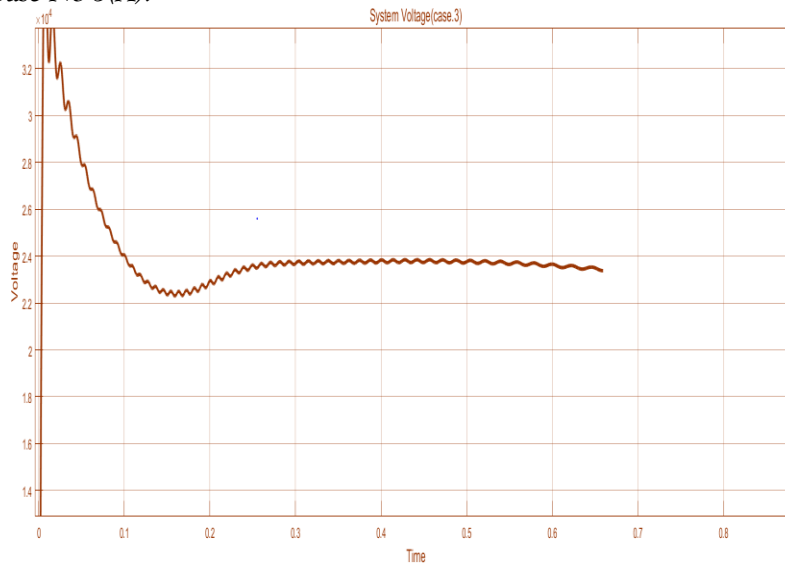

Figure 4.3.3. Demonstration of how the system voltage lowers from 25 KV to 24 KV when the connected load exceeds the power generated.

3(B). Table 4.4 below indicates when the demand is greater than the energy produced by the hydro generators while they are operating.

Table 4.4. Load is greater than Generated power and Hydro generators are on.

Kilo Watts Load	1600
PV(KW) in Power Generated	400
Kilo Watts Power Generated Wind Turbine	640
System Voltage (KW)	25
Pumping Power (KW)	Off
Hydro Generators Status	600
Total Power Generated (KW)	1040

The system was unstable in Example No. 3 (B), and the voltage dropped from 25 KV to 24 KV. In order to resolve this problem, we now let the hydro generators to produce electricity and steady the system voltage using the stored water from the higher reservoir.

Voltage graph in Case 3 (B):

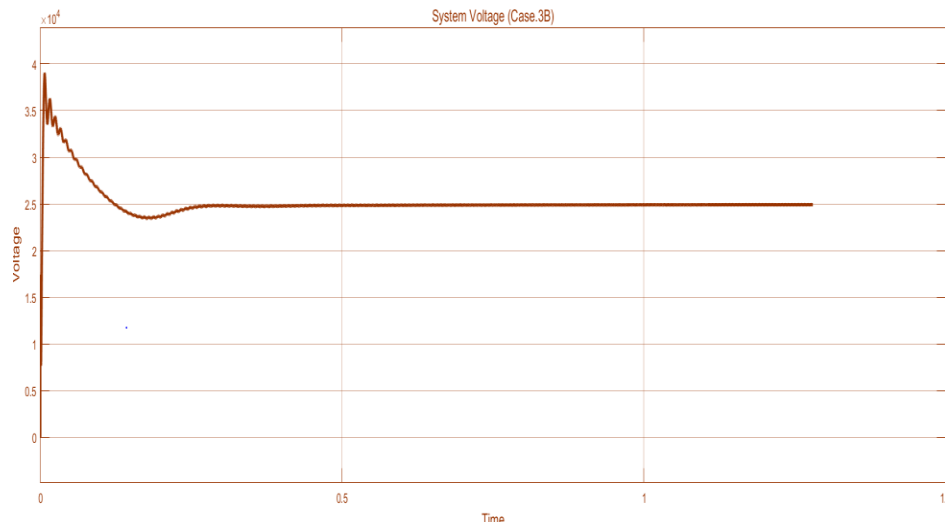

Figure 4.3.4. Demonstration of how the system voltage equalizes when we let the water stored in the higher tank drive water turbines to create power.

CALCULATIONS OF SOLAR PANELS

400KW Solar system calculation (400KW of output power and 25KV of output voltage).

Required current dc:

$$I = \frac{P}{V} \Rightarrow \frac{400KW}{12} \Rightarrow 33333A$$

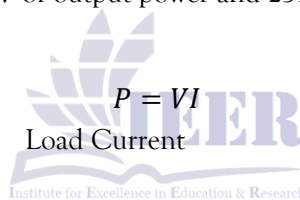

$$P = VI$$

Load Current

12V=150W, 24V

OR

48V = 250W

OR

325WSolar Panel

440W → Open Circuit → 49.5V

440W → Peak Voltage Solar → 40.5V

For Solar:

$$P = VI \Rightarrow 14 \times 33333 \Rightarrow 466662W$$

Number of Solar Panels:

$$\text{Number of Solar Panel} = \frac{P}{P_{\text{rated solar power}}}$$

$$= \frac{466662W}{440W} = 1060.6 \approx 1061 \text{ Solar Panel}$$

1061 solar panels with a combined output of 440W are employed in the 400KW solar system.

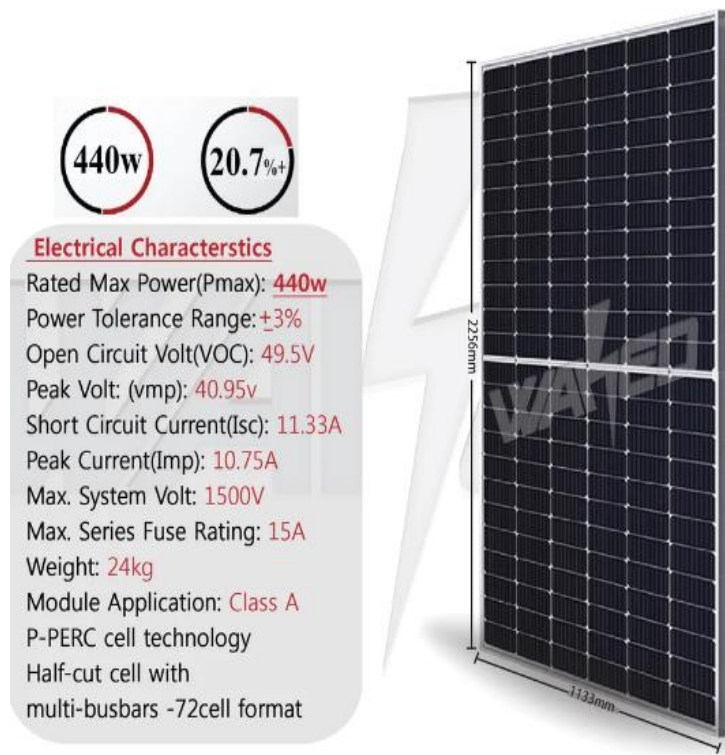

Figure 4.4 Electrical requirements for a solar panel with 440 KW of power

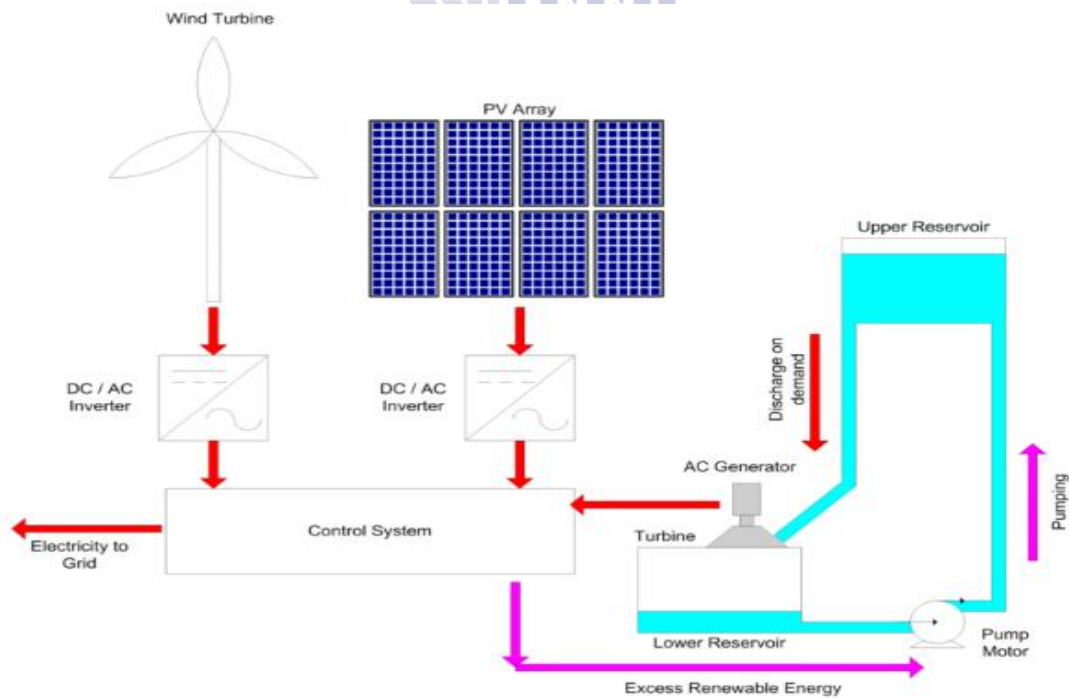

Figure 4.5 In order to integrate and integrate renewable energy sources and meet the growing need for grid station load, pumped hydro storage is being deployed in creative ways.

**CASE STUDY**

**RELATED WORK**

A benchmark study must be used to assess and compare the suggested integrated based model to alternative based models. The word "hydropower" refers to the generation of electricity using the force of flowing water. Hills and mountains become rivers and streams, which ultimately run into the ocean, as a result of precipitation and melting. The energy of that flowing water is converted into hydropower. This energy has been used for eons. Farmers have been using water wheels to crush wheat since the ancient Greeks. When a water wheel is immersed in a river, the water rushes into buckets arranged around it. The kinetic energy of the river is turned into mechanical energy, which powers the mill.

**LOCAL SUMMARY**

Around 48 kilometers from Dir City, in the Tehsil of UC Sher Palam, is the hamlet of Gor Kohi. District Dir upper includes the remote and steep area of Gor Kohi Kaley. It is made up of around 150 HHs. The primary means of subsistence and revenue was farming. The community lacks a health facility and only has one school for girls and one for boys. The Ushari Local River (stream) flows through the settlement. This stream originates in the snow-covered mountains, where there is an ample supply of water throughout the summer and winter. WAPDA line is absent. The settlement is located near UC Sher Palam on Kacha Road. Water, a natural resource, will be used by this PHES to meet the village's electrical demands.

**HYDRO POWER PLANT STORAGE CLASSIFICATION**

Hydro power plants storage classification is based on

- 1) Plant capacity
- 2) Head available

**PLANT CAPACITY BASED ON CLASSIFICATION**

Table 5.1. Plant capacity

Type	Capacity
Micro hydro power plants	<100KW
Mini hydro power plants	100KW to 1MW
Small hydro power plants	1MW to 10MW
Medium hydro power plants	10MW to 300MW
Large hydro power plants	>300MW

**BUILT ON HEAD TAXONOMY**

TABLE 5.2 LABELLING BUILT ON THE HEAD.

Type	Head
Low head plants	<15m
Medium head plants	15-70m
High head plants	70-250m
Very high head plants	More than 250m

**V.IV OBJECTIVES OF THIS SECTION**

In Hydro storage power plants (HSPP) are a typical energy source in developing nations. Since most HSPPs run in isolation and supply electricity to the surrounding rural areas with few populations, expanding the grid system would not be financially feasible. This is because constructing transmission lines requires a significant financial outlay. Hydroelectric power is the technique of generating electricity from the movement of water in rivers and streams. Water is injected into a turbine via a channel, influencing the turbine edges and causing the shaft to pivot. A generator is attached to the spinning shaft, converting its movement into electrical vitality. By employing these hydroelectric facilities, hydraulic operations may be made easy and large-scale construction, such as dams, is usually not necessary. Determining the power potential of the chosen site and designing its components is our primary goal.

**DESIGN METHODOLOGY**

Although the electrical component design of PHSP is the focus of our research, the civil component design of PHSP may also be defined. The numerical foundation for the hydro storage power plant's design is covered by design methodology. It entails identifying and assessing the processes needed to carry out the research from beginning to end as well as identifying some fundamental equations and relations that will be employed in the study. Measuring the discharge and head is the first stage in the PHS schemes. Once these characteristics are determined, it is simple to construct the hydraulic structures and electrical components that generate the needed discharge and lift.

**DESIGN OF HYDRAULIC**

For a PHSP to operate correctly, the hydraulic design is used to calculate the dimensions of every single civil component. Assume a water level for the diversion works' design discharge, then build the weir to store water before designing the intake structure. There is a Manning's equation for the power channel. Usually, this formula is applied to lined canals.

**DISCHARGE**

**FLOW IS THE TIME-RELATED FLOW VOLUME THROUGH HYDROGEN TO ANY POINT.**

**MEASUREMENT PROCEDURES OF DISCHARGE**

When creating a hydropower plan, outlet search should not be based on a single flow measurement; instead, measurements should be taken at regular intervals for at least a year.

The methods utilised to seek for discharge are as follows:

- 1) Technique of Velocity area.
- 2) Stream of Current meter.

**TECHNIQUE OF VELOCITY AREA**

A straightforward, traditional technique for determining discharge on a stream is the velocity area approach. This technique measures the stream's cross-sectional area as well as the water's mean velocity.

**Measurement of cross sectional Area (A)**

First, we take two places along the stream's width to get the cross-sectional area. After that, we split it into equal segments. We compute the water depth throughout each interval and use the relation to obtain the cross-sectional area stream of an item. On a stream, the area should be measured four or five times for precision.

$$A = \frac{(W_t + W_b)/2 \times (h_1 + h_2 + h_3 \dots h_n)/n}{\text{Eq (7)}}$$

$A_s$ ;

$W_t$  = Top width of the stream.

$W_b$  = Bottom width of the stream.

$(h_1 + h_2 + h_3 \dots h_n)/n$  = average depth of the stream along each interval.

**Velocity (V) measurement:**

We first measure a specific distance (L) along the stream's length in order to determine the water's velocity across it. Using the  $V=L/T$  Equation (8), we can then determine the time (t) that the floating item, or cork, will need to travel the chosen distance (L). We are able to obtain velocity. It is important to measure the velocity at many locations along the stream to ensure accuracy. We will use the average of all the velocities observed at

various locations along the stream to determine the discharge.

$$V = \frac{L}{T} \quad \text{Eq (8)}$$

Where, L = Selected length of the stream = 20 m

T= Time = 10 sec

$$V = \frac{20}{10} = 2 \text{ m/sec}$$

Thus discharge (Q) can be measured by using,

$$Q = V \times A \quad \text{Eq (9)}$$

Where, V is the velocity in the stream = 2 m/s

A is the cross-sectional area of the stream = 9.7 m<sup>2</sup>

$$Q = 2 \times 9.7$$

$$Q = 19.4 \text{ cusecs} = 0.824 \text{ cumecs}$$

### CURRENT METER STREAM

A tool for determining the velocity of the stream is the current meter. Compared to velocity found using the velocity area method, it provides a more accurate velocity value. A SHAFT AND A ROTATING ELEMENT KNOWN AS A PROPELLER MAKE UP THE CURRENT METER. The propeller's rotation is contingent upon the velocity of the stream. When the stream flow reaches the propeller, the current meter in this method is positioned at the desired depth in the stream. THE WHEELER TURNS The mechanical counter in the current meter counts the number of propeller revolutions. The formula for calculating this is as follows:

$$VELOCITY IS, V = ANS + B \quad \text{EQ (10)}$$

WHERE; V = VELOCITY OF STREAM IN M/SEC.

NS = NUMBER OF REVOLUTIONS OF PROPELLER.

"A" AND "B" ARE CURRENT METER CONSTANT.

### HEAD

1.1.1. The discharge and head are crucial resources in the design of any hydro storage power plant, as they are the factors that determine the total energy generated by the plant. The vertical distance between the stock intake and the turbine's axis is known as the head. The power generation will increase with the size of the head.

#### 1.1.2. Procedure to find out head:

As seen in figure 5.1, we can locate the head with the use of staff rods and a level. Level is adjusted using this way in between staff rods. The staff rod is held by one man at the desired location of the head, while another man uses a level to take a reading. After the reading is acquired, the level is moved to a different spot, and the reading is taken at the given level. The variation in reading can be explained by the height between the two locations. As seen in Figure 5.1, the rod is then kept in the same position while the level is moved to position B. By continuing this procedure, the head may be measured.

Total head,  $H = H_1 + H_2 + H_3$ , Head = 22 ft or 6.7m

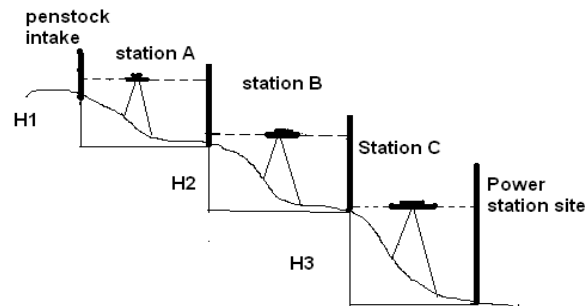

Figure 5.1. Measurement (Head)

After measuring the discharge and lift, lower the power.

#### POWER FROM AND PHSPP

It's important to understand the discharge and head available at the location in order to calculate the water's power potential. The power calculation formula is,

$$P = \rho \times H \times Q \times G \times \eta \quad \text{EQ (11)}$$

WHERE, P = ELECTRICAL OR MECHANICAL POWER PRODUCED, W

$\rho$  = DENSITY OF WATER, KG/M<sup>3</sup>

H = HEAD AVAILABLE AT THE SITE, M

Q = FLOW RATE OF WATER, M<sup>3</sup>/S

$\eta$  = OVERALL EFFICIENCY OF HSP

G = ACCELERATION DUE TO GRAVITY, M/S<sup>2</sup>

$P = 1000 \times 6.7 \times 0.824 \times 9.8 \times 0.75$

$P = 400 \text{ kW}$

1.1.3. Therefore, the equation shows that the amount of accessible water that may be used to create electricity depends on several factors, including elevation head and gravity force, water density, HSP efficiency, and flow rate. Because of things like turbine blades, penstock pipes, generators, and the final conversion from water potential energy to other forms of energy, the HSP set's efficiency of 0.75% is seen to be rather poor.

#### DIFFERENT COMPONENTS OF HSP

THE HSP'S COMPONENTS ARE SEPARATED INTO WEIR AND INTAKE STRUCTURE.

- a) POWER CHANNEL.
- b) TURBINE.
- c) PENSTOCK.
- d) FOREBAY.
- e) SETTLING BASIN.
- f) TRASH RACK CHANNEL.

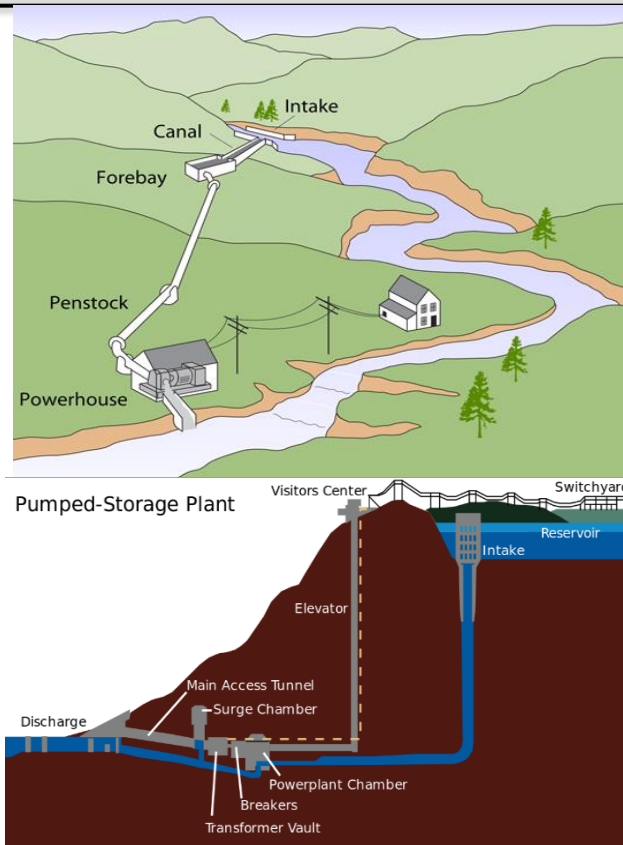

FIGURE 5.2. WHEN THIS SYSTEM IS USED, THE PLUM WILL GET WATER. CERTAIN GENERATORS CAN

### BE USED DIRECTLY ON THE FIELD.

#### STRUCTURE OF WATER AND ITS INTAKE

The dam spans the width of the stream. The HSPP dam's job is to drive water into the intake structure and raise the water level, rather than to store it. Reception is one of the most crucial aspects of the HSPP. The suction structure delivers water to the access canal. The suction structure includes a waste-cleaning equipment, garbage containers, gates, and valves. Flowing water contains bigger boulders, debris, logs, and so on, therefore garbage cans and debris equipment serve to keep debris, ice, rocks, and so on out of the channel. It also prevents significant sediment loads from entering the waterway through generic equipment.

#### CHANNELS (APPROACH OR POWER)

A channel transports water to the bow tank. Its length is substantially bigger and is determined by the object's topography as well as the distance between the power plant and the suction structure.

If water moving through a channel loses energy due to friction between the water and the channel's wall and bottom material, the rougher the channel, the greater the energy loss, necessitating a steeper gradient between the channel's entry and departure. The canal slopes so that running water does not erode the channel's bottom.

#### RESOLVING

The water transported by the canal contains small suspended particles that, if not stopped, may cause turbine wear and reduce turbine performance; thus, some construction is required to prevent these suspended particles, such as mud and sand. The sedimentation basin is located in front of the bow, and its primary function is to avoid the production of sand and silt particles, which may be accomplished by delaying canal water in the sedimentation basin owing to a drop in water speed. Water velocity can be decreased by

expanding the sediment basin's surface area, causing silt and sand particles to settle and allowing water to reach the bow without sediment. The settling basin's sludge and silt are then cleansed on a regular basis via a flow line that connects to the basin.

## FRONT COVE

Basin, or fore bay, is situated just before to penstock. The front cove is a large, deep pool that serves as a temporary storage area for water drawn from the canal by the penstock. It also functions as a reservoir for flow regulation, ensuring that the water enters the penstock smoothly and without turbulence. A scouring gate, a gate to penstock, an air vent, a garbage rack, and a spillway are some of the other crucial for bay components.

## SPILLWAY

Through the spillway, the fore bay tank's excess water flow is removed. There is a gate at the entrance to the penstock. When the gate is opened, water flows into the penstock for any turbine maintenance. When the gate is closed, the water from the front bay can no longer flow into the penstock, which makes maintenance easier for us.

## TRASH RACK CHANNEL

Similar to a power canal, which is also a channel but is smaller and situated close to the stream, a trash rack is a small open channel that returns water to the stream from which it originated. Water flows into the trash ranch channel from the turbine and back to the main stream, ensuring that no water is lost.

## AIR VENT

We sometimes close the gate, which causes negative pressure to build up within the penstock and may cause the pipe to collapse. To prevent this from happening, we have an air vent to lessen the vacuum pressure that builds up inside the pipe. At the penstock entry, screens are used to filter out big suspended particles.

## PENSTOCK

Penstock is a pipe that runs from the fore bay to the turbine, carrying water under high pressure. It is constructed from a variety of materials, including concrete, steel, polyvinyl chloride (PVC), and polyethylene. In order to transform the kinetic and potential energy of the water into pressure and velocity inside the penstock, the penstock should be mounted steeply. To decrease head misery in channels, the amount of vertical and flat twists should be kept to a minimum.

## PENSTOCK DIAMETER CALCULATIONS

$$A) D = (4 \times Q / 3.14 \times V)^{0.5} \text{ (A)}$$

“WHEREAS ‘Q’ IS THE DISCHARGE, V IS THE VELOCITY OF WATER”

$$B) D = (4 \times 0.824 / 3.14 \times 3)^{0.5}$$

$$C) D = 0.590 \text{ METER OR } 1.93 \text{ FT}$$

## WALL THICKNESS CALCULATIONS OF PENSTOCK

FORMULA:

$$TP = \frac{P \times D}{2 \times S \times E} + 0.1$$

- TP: THICKNESS OF THE PENSTOCK WALL
- P: PRESSURE
- D: INTERNAL DIAMETER OF THE PIPE
- S: SAFE WORKING STRESS OF THE PIPE
- E: QUALITY FACTOR OF THE PIPE

PRESSURE CALCULATION:

$$P = 0.4335 \times H_g$$

$$P = 0.4335 \times 22$$

$$= 9.537 \text{ PSI}$$

- HG: GROSS HEAD = 22 FT.

GIVEN VALUES:

$$S \text{ (SAFE WORKING STRESS)} = 7000 \text{ PSI}$$

$$D \text{ (INTERNAL DIAMETER)} = 1.93 \text{ FT. (23.16 INCHES)}$$

$$E \text{ (QUALITY FACTOR)} = 1$$

CALCULATION OF TP:

$$TP = \frac{9.537 \times 23.16}{2 \times 7000 \times 1} + 0.1$$

$$TP = 0.1157 \text{ INCHES}$$

$$TP \approx 3 \text{ MM}$$

OPERATIVE WIDTH

FORMULA:

$$TE = TP + CS$$

- CS: CORROSION ALLOWANCE = 1 MM

$$TE = 3 \text{ MM} + 1 \text{ MM}$$

$$TE = 4 \text{ MM}$$

## THE TURBINES

## CATEGORIES OF TURBINES

The two primary subtypes of water turbines are impulse turbines and reaction turbines. In a reaction turbine, the runners, or blades, are entirely immersed in water and shielded by a pressure casing. The runner rotates as a result of the slanted blades creating lift forces that resemble those found on airplane wings in the presence of pressure differences. Reaction turbines are most often used in low head applications. An impulse turbine has a runner that rotates while one or more water jets are impinging on it. A nozzle

changes pressure to turn a slow-moving stream of water into a rapid jet, much like a garden hose nozzle. Reaction turbine examples include the following: Francis Wheel, Kaplan (Propeller). Here are some instances of impulse turbines: Pelton, Turgo, and Cross Flow.

## TURBINES ASSORTMENT

When choosing a turbine for water-to-wire performance, available head and water flow are important factors to consider. Generally speaking, reaction turbines are employed with low head sites

and impulse turbines with high head sites. Moreover, the efficiency of different turbines varies to some extent when the flow and/or head deviate from the ideal design values due to their

different tolerances for fluctuations in flow and/or head. The following Table 5.3 illustrates the many uses for these basic turbine types.

Table 5.3 Primary Types of Turbines

Turbine Types	High Head	Medium Head	Low Head
<b>Impulse Turbine</b>	Pelton Turgo	Cross Multijet Turgo	Flow Pelton Cross Flow
<b>Reaction Turbine</b>		Francis	Kaplan

The related graph, Figure 5.3, displays each turbine's operating ranges with respect to head and flow rate.

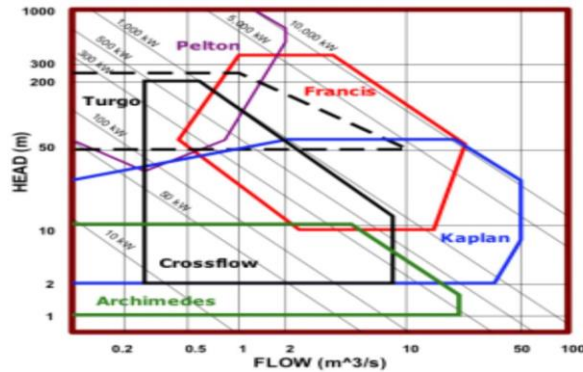

Figure 5.3. Chart depicts the working ranges of each turbine in terms of head and stream rate.

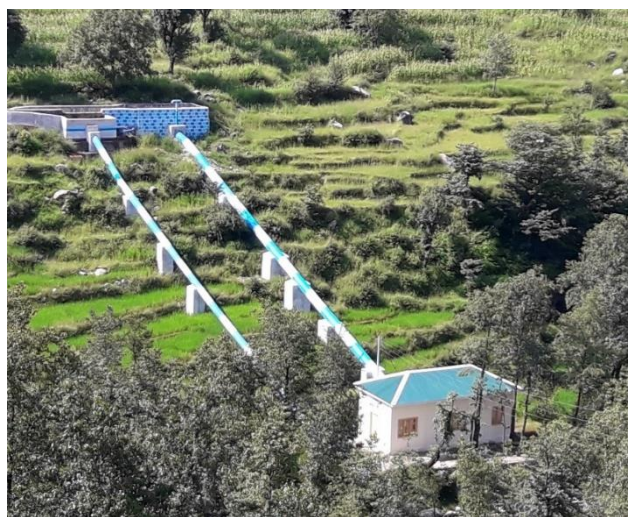

Figure 5.4. Occasion Learning

Given the head and stream rate values at the exhibited area (Case Consider) of 6.7 m for the head and 29.1 cusecs (0.824 m<sup>3</sup>/s) for the stream rate, a turbine with a general moo specific speed should be used. According to the chart above, the site plant should have one cross-stream turbine.

## CONCLUSIONS AND FUTURE PERSPECTIVES

### CONCLUSION

This system consists of a wind turbine, a control station, a pumped-hydro capacity system, a few photovoltaic (PV) sheets, and an end user (stack). When the system is connected to the system, the control station acts as the grid's torpidity capacity; however, it may also function independently of the cross-section or as a stand-alone system. Generally and by far the most cost-effective option is to store large amounts of renewable energy, taking into account factors such as construction costs, adequate geology, and climate change pressures [8].

The most important method for fiscally storing the massive amounts of grid energy that are currently available is pumped capacity, which increases the producing system's average capacity figure. When water is limited from a lower store to a higher one, essentiality is stored as potential vitality, allowing the turbine to exploit the water supply to generate the prescribed amount of essentialness [9]. This study suggests a pumped hydro capacity structure to meet the network's increasing stack requirements. Control plants may engage in contracts with the system to guarantee that they have the number of units necessary. Regardless, because wind and solar production vary, the control plant cannot provide enough electricity to fulfill demand.

I) To conserve vitality for periods when wind and sun-based control yields are high. When a request is large and the framework is unable to provide enough power to manage the stack, we will use this stored energy.

II) On occasion, we guarantee to provide the network with stationary devices powered by solar and wind energy. Regardless, due to the discontinuous character of both sources (sun and wind), we are frequently unable to keep this

pledge. Since then, we've used a hydro pump to store energy so that we can meet our obligations during periods of high demand.

III) To determine whether and where the system is workable. We'll investigate those regions from several angles where this technology may be used.

### ACHIEVEMENTS

- GET PAST YOUR ENERGY SHORTCOMINGS.
- CORRECTED THE INTERMITTENT NATURE OF THE SOLAR SYSTEM HYBRID WIND.
- MET THE GRID STATION'S OBLIGATION.

### FUTURE PERSPECTIVES

There are several methods and directions in which the work might be expanded. The most crucial directions are to reduce computing complexity and make the suggested models simpler. In this regard, since the processing time is within a tolerable range, a greater improvement in the electricity usage is anticipated. Better Estimation of energy solutions and achieving the desired and expected performance. Finding the discrepancy between the performance of the real system and the simulation findings is planned, and the results will be taken into consideration when developing hybrid systems in the future.

### ACKNOWLEDGMENT

We extend our heartfelt gratitude to the dedicated team for their invaluable collaboration in the data collection process. Their tireless efforts and unwavering commitment have been instrumental in the successful completion of this research paper.

### REFERENCES

- G. O. Young, "Synthetic structure of industrial plastics (Book style with paper title and editor)," in *Plastics*, 2nd ed. vol. 3, J. Peters, Ed. New York: McGraw-Hill, 1964, pp. 15-64.
- W.-K. Chen, *Linear Networks and Systems* (Book style). Belmont, CA: Wadsworth, 1993, pp. 123-135.
- H. Poor, *An Introduction to Signal Detection and Estimation*. New York: Springer-Verlag, 1985, ch. 4.

- B. Smith, "An approach to graphs of linear forms (Unpublished work style)," unpublished.
- E. H. Miller, "A note on reflector arrays (Periodical style—Accepted for publication)," *IEEE Trans. Antennas Propagat.*, to be published.
- J. Wang, "Fundamentals of erbium-doped fiber amplifiers arrays (Periodical style—Submitted for publication)," *IEEE J. Quantum Electron.*, submitted for publication.
- K. Rehman, Z. Ullah, "PackeX: Low Power High-Performance Packet Classifier Using Memory on FPGAs," *Hindawi Wireless Communications and Mobile Computing, Smart Antennas, and Intelligent Sensors Based Systems: Enabling Technologies and Applications* 2021. <https://doi.org/10.1155/2021/5544435>
- Ullah, I.; Hussain, I.; Rehman, K.; Wróblewski, P.; Lewicki, W.; Kavin, B.P. "Exploiting the Moth-Flame Optimization Algorithm for Optimal Load Management of the University Campus: A Viable Approach in the Academia Sector". *Energies* 2022, 15, 3741. doi: 10.3390/en15103741
- Albogamy, F.R.; Ashfaq, Y.; Hafeez, G.; Murawwat, S.; Khan, S.; Ali, F.; Aslam Khan, F.; Rehman, K. "Optimal Demand-Side Management Using Flat Pricing Scheme in Smart Grid". *Processes* 2022, 10, 1214. doi: 10.3390/pr10061214
- Ullah, S.; Hafeez, G.; Rukh, G.; Albogamy, F.R.; Murawwat, S.; Ali, F.; Khan, F.A.; Khan, S.; Rehman, K. "A Smart Sensors-Based Solar-Powered System to Monitor and Control Tube Well for Agriculture Applications". *Processes* 2022, 10, 1654. doi: 10.3390/pr10081654
- Khan, T.A.; Ullah, A.; Hafeez, G.; Khan, I.; Murawwat, S.; Ali, F.; Ali, S.; Khan, S.; Rehman, K. "A Fractional Order Super Twisting Sliding Mode Controller for Energy Management in Smart Microgrid Using Dynamic Pricing Approach". *Energies* 2022, 15, 9074. doi: 10.3390/en15239074
- Alzahrani, A.; Hafeez, G.; Ali, S.; Murawwat, S.; Khan, M.I.; Rehman, K.; Abed, A.M. "Multi-Objective Energy Optimization with Load and Distributed Energy Source Scheduling in the Smart Power Grid". *Sustainability* 2023, 15, 9970. doi: 10.3390/su15139970
- Khalid Rehman, Iran Ullah, Yasir Ullah, Izaz Ahmad, Irfanud Din, Danish Shehzad, "Design and Analysis of Multi-Layer Patched Efficient Antenna for 28-GHz Applications", *Pakistan Journal of Emerging Science and Technologies (PJEST Volume 4 Issue 3.123)*, June 2023. doi.org/10.58619/pjest.v4i3.123
- Khalid Rehman, Malik Altamash, Jan Sher Khan, Junaid Miraj, Zaheer, "A Network of Neural Model for Small Term Load Prediction Using Novel Feedforward (FITNET)" *Pakistan Journal Emerging Sciences and Technologies (PJEST)*, 2023. <https://doi.org/10.58619/pjest.v5i1.164>
- Syed Yasir Ahmad, Ghulam Hafeez, Khursheed Aurangzeb, Khalid Rehman, Taimoor Ahmad Khan and Musaed Alhusein, "A Sustainable Approach for Demand Side Management Considering Demand Response and Renewable Energy in Smart Grid", *Frontiers in Energy Research Process and Energy Systems Engineering-Smart Grids*, September, 2023. <https://doi.org/10.3389/fenrg.2023.1212304>
- Shahzaib, Khalid Rehman, Malik Altamash, Junaid Miraj, "Design Radial Distribution To Study Load-Flow and Short Circuit Analysis Using (ETAP) Software" *Pakistan Journal of Engineering and Technology (PAKJET)*, April, 2024.